



# Request for Tender

Reference Number #560000169

(Please refer to this number when making inquiries)

**Issue Date: June 07, 2021**

**Closing Date & Time: June 21, 2021 - 15:00 EDT**

**Nunavut Housing Corporation Directorate  
Procurement & Contract Support  
2<sup>nd</sup> Floor, Building 1553, Federal Road  
P. O. Box 1000 – Station 1400  
Iqaluit, NU X0A 0H0  
Fax Number: (867) 975-7270**

**Buyer: Maria Gumban  
Phone: 867- 975-7207  
E-mail [mgumban@gov.nu.ca](mailto:mgumban@gov.nu.ca)**

**Tenderer's Name and Address:**

**NNI Registration # \_\_\_\_\_ NTI Registration # \_\_\_\_\_**

**Tenderer's Authorized Representative (Print):**  
**Name: \_\_\_\_\_**  
**Phone: \_\_\_\_\_**  
**E-mail: \_\_\_\_\_**

**Special Instructions:**

1. For NNI Purposes the NNI Subject Community will be in [Sanikiluaq \(Qammaq\)](#), Nunavut.

**FOB Point:** All material shall be delivered FOB LHO warehouse within [Sanikiluaq](#). Successful contractor is solely responsible to ensure that the designated Government of Nunavut marine carrier and local cartage is used.

**Supplementary Instructions to Tenderers:**

1. The NNI Regulations applies to this RFT. All bids are subject to the Instructions to Tenderers attached herewith as Appendix A. To be considered, all Bids must be on this Bid Form and signed by the Tenderer's authorized representative in the space provided below. A completed and signed Declaration of Conformity must also be submitted as part of the Bid.
2. **Tenderers must provide unit pricing for each item and calculate the total net bid price for all items offered on this Bid Form.** In the event of a conflict or mathematical error, the unit prices shall govern. All prices bid must be in Canadian dollars exclusive of GST. The NHC does not pay Provincial Sales Taxes (PST). **Where unit prices are not provided for any of the line items, the bid will be deemed not Responsive and will be disqualified.**
3. By signing this Bid Form and submitting a bid, the Tenderer hereby acknowledges and agrees that should their bid be accepted by the Buyer, they will be bound to deliver the goods described herein, at the prices tendered below, in accordance with the Purchase Order Terms and Conditions attached herewith as Appendix B.

ITEM	DESCRIPTION	DELIVERY DEADLINE	UNIT	PRICE	QUANTITY	TOTAL
1	<p>Materials as per Appendix "C"</p> <p>All material shall be delivered during the 2021 Sealift season using the "Designated Government of Nunavut Marine Carrier" for <a href="#">Sanikiluaq ( Qammaq)</a>.</p> <p>Bidders are to make a lot bid from the totals of Community's Appendix C and place on this tender form.</p> <p>Please be advised that the successful bidder shall be required to submit crate list, detailed packing slips that show the item number, description and shop drawings upon delivery to the designated carrier. No payments will be released until this has been received in a form that is satisfactory to the NHC.</p>	1 <sup>st</sup> Sailing	Lot			
<p><b>Specify Delivery Lead Time: _____</b></p> <p><b>THIS IS NOT A PURCHASE ORDER.</b></p>						

**Tenderers's Authorized Representative (Signature)**

**TOTAL**

# RFT Goods Tender & Purchase Order

## APPENDIX A - INSTRUCTIONS TO BIDDERS

Reference Number RFT # 560000169

(please refer to this number when making inquiries)

**DEFINITIONS:** For the purposes of this Request for Tenders and Purchase Order process

- i) "Bid" or "Tender" means an offer by a Bidder, to supply the goods requested by NHC in this Request for Tenders (RFT) at the prices submitted by the Bidder on the Bid Forms provided herein, which will be subject to acceptance by the Buyer under the terms and conditions of this Appendix A.
- ii) "Bidder" means any legal entity in the business of supplying goods who may submit, or has submitted, a bid in response to this RFT;
- iii) "Buyer" means the representative, authorized by the Contracting Authority, to request Tenders and issue Purchase Orders on behalf of NHC;
- iv) "Contract" or "Purchase Order" means the goods supply contract between NHC and the successful Bidder as a result of this RFT. It will consist of the accepted Bid, signed by the Buyer, and the Purchase Order Terms and Conditions set out in Appendix B hereto, and any other limited terms, conditions or additional quantities as may be mutually agreed to between the Buyer and the Bidder, and will be identified as a Purchase Order. The resulting Contract will be issued to the Supplier by way of facsimile or electronic transmission and will automatically take effect upon the date of issue by the Buyer to the Supplier.
- v) "Contracting Authority" means the Minister, or Deputy Minister, of the department of Nunavut Housing Corporation within the Government of Nunavut (GN);
- vi) "NHC" means The Nunavut Housing Corporation;
- vii) "Responsible" means, in relation to a Bidder, the capability in all respects to perform fully the Contract requirements and the integrity and reliability to assure performance of the Contract obligations;
- viii) "Responsive" means, in relation to a Bidder, that the Bidder has submitted a Bid which conforms in all material respects to the RFT;
- ix) "Supplier" means the legal entity Bidder who is responsible, and who has submitted the bid that is responsive, and after application of the NNI Regulation is lower than that of any other Bidder, and is issued a Purchase Order as a result;

## RULES FOR SUBMITTING

1. **BIDDERS MAY FAX TENDERS** in accordance with the following conditions:
  - a) Transmissions must be sent only to the fax number identified in the Closing Address and Location section of the Bid Form.
  - b) Transmissions must be received in their entirety on or before the exact time and date fixed for the receipt of quotes. For greater clarity, 'received in its entirety' means that all pages of the tender submission, including single page bids, must be fully printed by the receiving fax machine on or before the stated closing date and time, and such tender submissions will not be considered received until all pages of the fax transmission are completely printed.
  - c) It is the Bidder's sole responsibility to confirm with the Buyer that the transmission has been received in its entirety on or before the closing time.
  - d) While NHC will undertake to handle fax submissions in a secure and confidential manner, it is impossible to guarantee the confidentiality of information contained therein; therefore, by faxing their bid, the Bidder waives any legal claim of confidentiality against NHC.
  - e) NHC shall not be held liable for any claim, demand or other actions for any reason should a facsimile transmission be illegible, garbled, incomplete, interrupted, not received in its entirety, received after stated closing time and date, received by any fax machine other than the one stated herein, or for any other reasons or risks associated with faxing tenders.
2. **NUNAVUT TENDERS BID BOX:** NHC is offering vendors the option of submitting bids electronically for some, but not all, tenders and requests for proposals, using the Nunavut Tenders website (<http://www.nunavuttenders.ca>). If this RFT is eligible for the Nunavut Tenders Bid Box, a "Submit" button will appear on the webpage. By using the Bid Box, Bidders are agreeing to the Terms of Use, which are linked to the Nunavut Tenders webpage.
3. Due to limited bandwidth, file size restrictions and connectivity interruptions, Bids submitted by e-mail will not be accepted under any circumstances, and will be rejected as misdirected Tenders.
4. Bidders are required to complete the Bid Form and Declaration of Conformity in their entirety and submit them, and any other required tender forms, to the closing address and location, or fax number stated therein, on or before the closing date and time stipulated on the face of the RFT bid form.
5. Bidders must bid on each and every item listed or the bid will be non-compliant.
6. ~~The GN reserves the right to accept Bids in whole or in part and award separate Contracts based on unit pricing.~~

# RFT Goods Tender & Purchase Order

## APPENDIX A - INSTRUCTIONS TO BIDDERS

Reference Number RFT # 560000169

(please refer to this number when making inquiries)

7. Verbal responses to any question, whether by the Buyer or any other person, shall not be relied upon by the Bidder and shall not be binding on the Buyer or NHC.
8. The only authorized contact in relation to this RFT is the Buyer identified in the Buyer Information section on the Bid Form. Questions regarding this RFT should be in writing and received by the Buyer at least 2 working days before the closing date and time. A response to any question received after this deadline is not guaranteed.
9. NHC reserves the right to make any amendment to this RFT at any time prior to the closing date and time, including amending the specifications and the closing date and time. In such an event the Buyer will endeavour to formally notify all Bidders by way of an addendum, or other reasonable means, as soon as practically possible prior to the tender closing date and time.
10. Unless otherwise stated, equivalents to the items detailed in this document are encouraged. Where materials are required to conform to "Standards Specification" (i.e., CSA, CGSB, ASTM), or are described by a trade name, model or manufacturer, this is for the purpose of establishing and defining the nature and minimum quality acceptable and is not meant to prevent Bidders from offering alternative goods; nor does it preclude NHC from considering or accepting alternatives.
11. Bidders should provide, along with the Declaration of Conformity, all documents that clearly show that the alternative(s) offered are equal to, or exceed the standards specified. NHC, in its sole discretion reserves the right to determine whether the alternative is compliant or not.
12. Where a "trade-in" is tendered in lieu of a specified item, it shall be identified in the Declaration of Conformity Bid form and the amount of credit offered for the trade-in must be stated separately from the quote offer for the required item(s). Trade-ins or alternatives may not necessarily be accepted. Bidders should question the Buyer in accordance with these Instructions.
13. In the case of an RFT for Mobile Equipment, NHC has relied on information provided by manufacturers to develop a specification for equipment with a specific purpose. Should the Bidder determine that any option, specification, attachment or accessory is either not available or not recommended then the Bidder should advise the Buyer prior to the closing date and time.
14. Goods or equipment requested in this RFT shall be protected by a minimum twelve (12) month manufacturer's warranty and NHC shall be the direct beneficiary of such warranty; therefore, Bidders are required to submit the particulars of all warranties as part of the Bid. Failure to provide warranty details, including costs, information on service depot, field and remote location, crew and service capabilities may result in the Bid being disqualified.
15. One of the priorities of NHC is to ensure that Nunavut, Inuit and Local materials, equipment and labour are used in NHC contracts; therefore, the "Nunavummi Nangminiqatunik Ikajuuti (NNI Regulation) applies to this RFT. The NNI Regulation permits Nunavut, Inuit and Local adjustments to the bid amounts of companies listed in the NNI Registry ([www.nni.gov.nu.ca/search](http://www.nni.gov.nu.ca/search)) or in the NTI Inuit Firm Database (<http://inuitfirm.tunnngavik.com/search-the-registry/>). For the purposes of ensuring the correct bid adjustments are applied, Bidders should indicate their NNI and NTI Registration Numbers on the RFT Bid Form.
16. The Bidder warrants that its bid was submitted without collusion between itself and any other Bidder.
17. The GN's "Access to Information and Protection of Privacy Act (Nunavut) S.N.W.T. 1994, c. 20" (the Act) will define NHC's responsibilities with respect to any information received by it pursuant to this RFT process. Subject to the Act and any applicable law, tenders and all related information shall be treated as confidential and shall not be disclosed to any person except with the consent of the Bidder or Supplier and to the extent disclosure is required to fulfill obligations under this RFT or pursuant to any applicable law.
18. NHC's contracting activities are undertaken with public funds, and are therefore subject to public reporting requirements. Annually, NHC releases a detailed Procurement Activity Report (PAR) which identifies the winning Bidder, the Purchase Order award method and award value along with other pertinent information.
19. Bidders may amend or withdraw their tender submission at any time before the stated closing date and time but not after. Amendments may be submitted by facsimile transmission in accordance with the provisions of rule 1 above, and should indicate only the applicable changes in such a manner that the total bid price is not revealed. If bidding via the Nunavut Tenders Bid Box is permitted, Bidders may upload a revised Bid.
20. Late, incomplete or misdirected Bids will not be accepted.

# RFT Goods Tender & Purchase Order

## APPENDIX A - INSTRUCTIONS TO BIDDERS

Reference Number RFT # 560000169

(please refer to this number when making inquiries)

21. NHC is not liable for any costs of preparation or presentation of any Tenders. All Bids and accompanying documentation received by NHC in response to this RFT shall become the property of NHC and will not be returned.
22. Notwithstanding any other provision, a Bidder who submits a Bid in response to this RFT agrees that NHC's liability for any claim for damages or compensation of any kind related directly or indirectly to a breach of contract or other cause of action arising from this RFT process, shall be limited to the Bidder's actual Bid preparation cost. Bid preparation cost is the actual cost borne by a Bidder to prepare and submit its response to this RFT. By submitting a Bid to this RFT a Bidder acknowledges and accepts this limitation.

### SHIPPING AND PRICING

23. Prices must include all charges for containers, packing and cartage to the FOB point and NHC shall not be bound to pay any additional separate freight or shipping charges not identified in the bid.
24. The Bidder will, where applicable, accurately state the gross shipping weight, as well as the height, width and length of any shipment, in metric terms.
25. Where one or more FOB points are identified in this RFT, prices and costs must be shown separately for each stated FOB point.
26. Freight rates shall be consistent with the GN's contracted air freight and sealift rates which are available from the Buyer on request. For goods requiring marine transportation, the sealift freight rates contracted by the GN with sealift carriers apply. For goods requiring air transportation, the GN's Standing Offer rates with air carriers apply. If additional information is required, it should be requested from the Buyer in accordance with the instructions herein.

### EVALUATION AND AWARD

27. It is a condition of this RFT that any resulting contract award hereunder is subject to section 46 of the Financial Administration Act, as amended, which provides as follows:  
*"It is a condition of every Contract made by or on behalf of the government requiring an expenditure, that an expenditure pursuant to the Contract will be incurred only if there is a sufficient uncommitted balance in the appropriated item for the fiscal year in which the expenditure is required under the Contract."*
28. Bids shall be opened as soon as practicable after the stated closing date and time. Bids may be opened at a public opening in which only the Bidder's name and price, amendments, and where applicable, bid security will be announced. Thereafter, Bids will be evaluated based upon the price, the responsiveness of the tender, the responsibility of the Bidder, and application of the NNI Regulation.
29. Bids received by NHC on time shall, upon the closing date, remain valid, irrevocable and open for acceptance by NHC for a period of ninety (90) days.
30. NHC does not accept any condition, reservation, customary or otherwise, subject to which the Bidder may purport to sell, ship or deliver the goods other than those stated herein.
31. The lowest or any tender may not necessarily be accepted. If a Contract is to be awarded as a result of this RFT, it will be awarded to a compliant Bidder who is responsible, and has submitted a bid that after application of price adjustments permitted by the NNI Regulation, is lower than that of any other Bidder.
32. NHC reserves the right to make adjustments to a Bid following bid closing in accordance with the NNI Regulation by taking into account any information that will assist it in doing so, including by taking into account information obtained from the NNI Business Directory maintained by the NNI Secretariat and the Inuit Firm Registry maintained by NTI. For greater certainty, if NHC determines that a bidder should, or should not, receive a bid adjustment pursuant to the NNI Regulation, it can adjust the evaluation of the bid accordingly.
33. NHC reserves the right to accept or waive any minor informality or minor non-compliance with these Instructions to Bidders or other requirements; however, a substantial or material non-compliance shall not be waived.

# RFT Goods Tender & Purchase Order

Reference Number RFT # 560000169

## APPENDIX A - INSTRUCTIONS TO BIDDERS

(please refer to this number when making inquiries)

34. NHC reserves the right to cancel this RFT at any time during this process, and to revise and re-issue new or similar requirements thereafter, for any reason whatsoever, without incurring any liability; and no Bidder will have any claim against NHC as a consequence.
35. Where the total Bid price is determined by unit pricing and estimated quantities, the Bid will be evaluated on the unit prices and estimated quantities rather than the total Bid price. The total bid price will be verified by the Buyer to confirm there are no mathematical errors in the Bidder's calculations. In the event of an error or discrepancy, the unit prices shall govern and the total Bid price shall be based upon the corrected mathematical calculation. The nature of the error will be considered in evaluating whether the bid is compliant.
36. NHC reserves the option of requesting complete details of the Bidder's warranty particulars and service capabilities. Failure to provide information sufficient to satisfy the requirements of this RFT may result in the Bidder bid being deemed 'Not Responsible' and disqualified from further consideration.
37. A Bidder found to be lacking the responsibility or capability to assure proper performance of the Contract, or delivery of the goods, may be deemed 'Not Responsible' by the Contracting Authority for the purposes of this RFT. A Bidder who has defaulted on a Purchase Order for similar goods within the last twelve (12) months may also be deemed Not Responsible by the Contracting Authority and prohibited from future RFTs until such time as the Bidder can satisfy NHC that it has corrected all documented deficiencies and grievances against it.
38. The Electrical Protection Act, R.S.N.W.T. (Nu.) 1988, c. E-3 (Nunavut) prohibits the sale, installation or use of uncertified electrical products in Nunavut. Therefore, any items or products provided by the Supplier that are electrical in nature or that are operated by electrical energy or contain electrical components must be certified by the Canadian Standards Association (CSA).

(please refer to this number when making inquiries)

### Declaration of Conformity

**BIDDERS MUST SIGN & SUBMIT THIS FORM TO BE CONSIDERED RESPONSIVE**

**Material Conformity:** The Bidder hereby acknowledges and agrees that the bid must be fully compliant with all mandatory requirements in order for the bid to be considered.

**Substantial Conformity (Bidder Options & Substitutions):** When an exception or alternative is proposed regarding a specified product, it will be evaluated to ensure that the performance capability meets the minimum requirements. The Bidder acknowledges and agrees that listing an exception or alternative does not necessarily constitute compliance with the specification, and that acceptance is subject to NHC's satisfaction that the exception or alternative does not constitute a material non-compliance with a mandatory requirement. Bidders are strongly encouraged to seek pre-approval from NHC prior to the stated Closing Date and Time.

<b>NHC REQUIREMENTS/SPECIFICATIONS THAT WILL NOT BE MET BY SUBMISSION</b>		
The Bidder hereby identifies the following exceptions or alternatives to the products specified on page 1.		
<b>Item Reference #</b>	<b>Exception/Alternative</b>	<b>Performance Capability</b>

If more space is required, photocopy and attach additional pages. Bidder should indicate the RFT Reference No., "Cont'd" and initial each additional page.

This declaration forms an integral part of the tender and shall be signed by the Bidder and included with the bid submission as per the Instructions to Bidders.

**Signed by Bidder's Authorized Representative**

\_\_\_\_\_  
Name & Title

\_\_\_\_\_  
Date

## DEFINITIONS

- i) “Buyer” means the representative, authorized by the Contracting Authority, to request Tenders and issue Purchase Orders on behalf of the NHC;
- ii) “Contract” or “Purchase Order” means this goods supply contract between NHC and the Supplier entered into as a result of a Request for Tenders (RFT). It consists of the accepted tender and the Terms and Conditions set out in this Appendix B hereto, and any other limited terms, conditions or additional quantities as may be mutually agreed to between the Supplier and the Bidder, and is identified as a Purchase Order. This Contract takes effect upon the date of issue by the Buyer to the Supplier.
- iii) “Contracting Authority” means the Minister, or Deputy Minister, of the department of Nunavut Housing Corporation (NHC) within the Government of Nunavut (GN);
- iv) “FOB” means Free on Board – Freight Prepaid and indicates the location at which ownership and responsibility for the goods transfers to NHC. For the purposes of this Contract, the Supplier shall be responsible for and bear all freight charges, own the goods in transit and will file any damages or claims incurred during shipping.
- v) “NHC” means the Nunavut Housing Corporation;
- vi) “Supplier” means the party to this Contract whose bid was accepted by the Buyer, and who, as a result, is now bound to supply the goods requested by NHC at the prices tendered, under the Terms and Conditions herein;

## GENERAL

1. This Contract shall be interpreted and governed in accordance with the laws of Nunavut and the laws of Canada as they apply in Nunavut.
2. It is a condition of this Contract that payment hereunder is subject to section 46 of the Financial Administration Act, as amended, which provides as follows:  
*“It is a condition of every contract made by or on behalf of the government requiring an expenditure, that an expenditure pursuant to the contract will be incurred only if there is a sufficient uncommitted balance in the appropriated item for the fiscal year in which the expenditure is required under the contract.”*
3. This Contract supersedes all previous communications, negotiations, representations and agreements, whether written or verbal and whether express or implied, unless expressly incorporated by reference in this Contract.
4. NHC does not accept any condition, reservation, customary or otherwise, subject to which the Supplier may purport to sell, ship or deliver the goods other than those stated herein.
5. No employer-employee, principal-agent or partnership relationship of any kind, between the parties, is intended or deemed to be created by this Contract.
6. This Contract shall enure to the benefit of and be binding on the administrators, executors, successors and assigns of both parties.
7. Any clarification of, amendment to, or alteration of any term or condition of this Contract may be made mutually only by the Contracting Authority or their duly authorized delegate and the Supplier’s duly authorized representative, and no other NHC or Supplier employee. Such clarification of, amendment to, or alteration of any term or condition of this Contract, including but not limited to subsequent increases in quantities of goods specified, shall be made and agreed to in writing prior to the agreed delivery time limit set out herein.
8. The Contracting Authority may delegate any of his/her authority and undertaking pursuant to this Contract to any other Minister, officer, employee or agent of NHC.
9. The failure by either party to insist upon strict compliance with any part of this Contract shall not prejudice the party’s right to insist upon strict compliance in the future.
10. In the event any provision of this Contract or any part thereof is declared to be unenforceable, the remainder of this Contract shall survive and remain in full force.
11. No waiver by either party of any part of the Contract shall be effective unless in writing and signed by both parties.

## **SUPPLIER'S RIGHTS AND OBLIGATIONS**

12. At all times during the performance of this Contract, the Supplier shall abide by and comply with all laws, regulations, by-laws and policies of NHC or Canada, as applicable, with regard to the sale, supply and delivery of goods.
13. The Supplier agrees to perform this Contract, formed as a result of an RFT process and resulting issuance of a Purchase Order, in full accordance with these terms and conditions and to the satisfaction of NHC.
14. This Contract may not be assigned or sub-contracted by the Supplier, either in whole or in part, without the prior written consent of NHC. It is acknowledged that in the case of certain contracts, it is obvious that certain portions of the goods might only be obtained by the Supplier from a third party and in such an instance it shall not be considered to be assigned or sub-contracted for the purpose of this article.
15. In consideration of the Supplier's full satisfactory delivery of the goods governed by this Contract, NHC agrees to pay the Supplier, in full satisfaction, the sums tendered and agreed to as a result of the RFT process; subject only to the payment terms and conditions contained herein.
16. Delivery of the goods by the Supplier shall be made within the time limits and in the manner stipulated in these Contract documents, including any specifications attached herewith. Time and delivery shall be of the essence.
17. The Supplier will be responsible for obtaining all permissions, permits, rights, licenses and warranties from all agencies, levels of government and/or government departments, dealers or other suppliers, which may be necessary or required by any law in order for the Supplier to carry out the terms of this Contract.
18. All goods or materials supplied shall be new, of merchantable quality, free of any defects and deficiencies, fit for their intended purposes, and in complete conformance to the specifications, drawings, plans or samples specified in this Contract.
19. All goods supplied shall be subject to inspection and may be rejected, returned or re-supplied at the Supplier's sole expense if they are found to be not acceptable to NHC, or not in accordance with the specifications of this Contract, and shall be returned to the Supplier.
20. The Supplier warrants that all materials delivered will be free from defects and conform to the specifications, drawings and samples specified by the Contract Authority; that this warranty shall survive any inspection, delivery, acceptance, or payment made by the Contract Authority of or for the materials and the purchaser may reject and return, at the risk and expense of the Supplier, any materials which are defective or do not comply with the said specifications, drawings and samples.
21. Title to any report, drawing, photograph, plan specification, model, prototype, pattern, sample design, logo, technical information, invention, method or process and all other property, work or materials which are produced by the Supplier in performing this Contract or conceived, developed or first actually reduced to practice in performing this Contract (herein called "the property") shall vest in NHC and the Supplier hereby absolutely assigns to NHC the copyright in the property for the whole of the term of the copyright.
22. Where applicable, installation shall include unloading materials, moving to site, assembly in accordance with floor plan, and fastening in place, as well as cleanup and clearing of site. Wherever possible, the use of local labour to aid in the installation phase, under the direct supervision of the Supplier, is encouraged.
23. The Supplier agrees that, if incorporated, in accordance with section 281(1) of the Business Corporations Act, S.N.W.T. (Nu.) 1996, c. 19 it will be registered with the Nunavut Corporate Registrar within 30 days of commencing business in Nunavut.
24. OPTION: The Supplier grants NHC an irrevocable option, which can be exercised at the sole discretion of NHC within 60 days of the issue date of this Purchase Order, for an additional quantity at the same price stated herein.

## **SHIPPING AND HANDLING**

25. The Supplier shall ensure that any goods or materials classified as "DANGEROUS GOODS" pursuant to either the Transportation of Dangerous Goods Act, 1992, S.C. 1992, c. 34, (Canada), or the Transportation Of Dangerous Goods Act, 1990, R.S.N.W.T. (Nunavut), shall be properly packaged, labeled, and shipped in accordance with such Acts.



**APPENDIX B – Purchase Order Terms & Conditions**

(please refer to this number when making inquiries)

26. The RFT and PO Reference Number for this Contract must be clearly shown on all invoices, packing slips, express receipts, Bills of Lading, and on all packing cases and each separate piece of material, as well as all relevant correspondence.
27. The Supplier shall state gross shipping weight as well as height, width and length dimensions in metric on all packing slips, waybills or bills of lading.
28. The Supplier must conform to all Supplier responsibilities applicable under the Worksite Hazardous Materials Information System (W.H.M.I.S.) regulations, pursuant to the Safety Act, R.S.N.W.T. 1988, c. S-1 (Nunavut) as amended.
29. The Supplier may be required to make the goods available for a pre-shipment inspection prior to any crating, containerization or any other form of packaging. The pre-shipment inspection shall be performed by NHC or its agents at a predetermined location and shall not, in any event, constitute acceptance by NHC. Acceptance shall only occur at final destination, upon receipt of the goods and final inspection satisfactory to NHC.

**INDEMNITY AND INSURANCE**

30. The Supplier shall indemnify and hold harmless NHC, its officers, employees, servants and agents from and against all claims, actions, causes of action, demands, losses, costs, damages, expenses, suits, settlements or other proceedings by whomsoever made, brought or prosecuted in any manner based upon, arising out of or related to, directly or indirectly, the activities or performance of the Supplier under this Contract; including an infringement or alleged infringement of any kind of intellectual property right.
31. The Supplier shall be liable to NHC for any loss or damage to property or equipment that is supplied to or placed in the care, custody or control of the Supplier for use in connection with the Contract whether or not such loss or damage is attributable to causes beyond the Supplier's control.

**CONFIDENTIALITY**

32. All information obtained from, supplied to, or otherwise concerning NHC or any of its agents, employees, clients, contractors or suppliers, in the performance of this Contract, shall be and remain confidential. The Supplier shall take all necessary steps to maintain such confidentiality and secure such information at all times. The Supplier shall return or destroy all such confidential information immediately upon notice from NHC, or in any event, upon satisfactory completion of this Contract.
33. The Supplier may be required, as a condition of this Contract, to sign a Non-Disclosure Agreement; without liability, cost or expense to the NHC.

**TERMS OF PAYMENT**

34. Provided all terms and conditions on the part of the Supplier have been complied with, each invoice, shall be paid thirty (30) calendar days after receipt of the invoice, or thirty (30) calendar days after delivery of the goods, whichever is later.
35. Provided all terms and conditions on the part of the Supplier have been complied with, invoices from a Nunavut Business, as defined by the NNI Regulation, shall be paid twenty (20) calendar days after receipt of the invoice, or twenty calendar days after receipt of the goods, whichever is later.
36. In addition to its rights under this Contract, NHC specifically reserves the following rights:
  - a) to deduct or set off any monies owed or due to NHC from any monies owed to the Supplier under this or any other contract;
  - b) to do any act NHC deems necessary to remedy or rectify any failure of the Supplier to perform its obligations under this Contract, and to set off the costs of such remedy or rectification from any monies owed to the Supplier under this or any other contract;
  - c) to hold back, in whole or in part, any payment due or becoming due to the Supplier without penalty, liability or expense in the event the Supplier is, in the opinion of NHC, failing to perform its obligations under this Contract; until such time as the breach is cured to the full satisfaction of the NHC.
37. The hold back will be disbursed upon:
  - a) satisfactory delivery of the goods in accordance with this Contract;
  - b) all damaged items are replaced and/or repaired so that they are deemed to be in compliance with the specifications; or
  - c) upon final delivery and inspection to the satisfaction of NHC.

38. The NHC's rights under this Contract are in addition to any rights and remedies it may have in law or equity.

#### **TERMINATION**

39. In the event of any actual or threatened labour disruption which may, or could, delay the timely performance of this Contract in any way, directly or indirectly, the Supplier shall forthwith provide written notice to NHC detailing the circumstances, causes and anticipated outcome of such disruption. NHC reserves the right and sole discretion in such an event, to terminate this Contract in whole or in part, without penalty, liability or cost, and may give written notice to this effect to the Supplier.
40. NHC reserves the right in its sole discretion to terminate this Contract at any time, without notice or compensation, if in the opinion of NHC:
- the Supplier has failed to perform its obligations under this Contract in a satisfactory manner, including failure to deliver the goods by the required delivery deadline;
  - the Supplier's performance under this Contract, or any other NHC contract, is persistently faulty;
  - the Supplier has or is about to become insolvent or commit an act of bankruptcy; or
  - for any other reason contemplated or described in this Contract.
41. NHC further reserves the right in its sole discretion to terminate this Contract in whole or in part for any reason upon thirty (30) calendar days' written notice to the Supplier.
42. Failure to comply with these terms and conditions may result in termination of this Contract with no liability on the part of NHC for any losses, damages, expenses or costs incurred by the Supplier.
43. In the event this Contract must be terminated, NHC reserves the right to exercise all available remedies including, but not limited to the recovery of damages.
44. In the event of termination, in whole or in part, NHC shall only be liable to the Supplier for its fees and costs, properly incurred and accounted for, pertaining to the satisfactory performance of this Contract, and nothing thereafter. NHC further reserves the right to exercise all available remedies against the Supplier, including but not limited to recovery of damages, and deeming the Supplier Not Responsible for future RFTs of a similar nature.

#### **FORCE MAJEURE**

45. Neither party shall be responsible for any delay or failure to perform its obligations under this Contract where such failure or delay is due to fire, flood, explosion, war, embargo, governmental action, terrorism, act of a public authority, Act of God or any other cause beyond its control, except labour disruption, without additional notice.
46. The Supplier acknowledges that Nunavut frequently experiences severe weather, shortages in supplies and fuel, and interruptions of power service and communications that might constitute force majeure elsewhere, and the Consultant will plan for those eventualities as much as possible.
47. In the event a Force Majeure event occurs which delays or threatens to delay performance of its obligations by a party, that party shall give prompt notice to the other party and shall take all reasonable steps to eliminate the cause or ameliorate the potential disruption and consequent losses.
48. Should the Force Majeure event last for longer than thirty (30) days, NHC may terminate this Agreement, in whole or in part, without further liability, expense or cost of any kind.

#### **ALTERNATIVE DISPUTE RESOLUTION**

49. Amicable Negotiations: As it is the intention of the parties to seek to resolve disputes without resort to litigation, the parties hereby agree that each of them shall make good faith and bona fide efforts to resolve disputes by amicable negotiations between their respective representatives as expeditiously as possible and shall provide frank, candid and timely disclosure of all relevant facts, information and documents to facilitate those negotiations. During such negotiations, the parties agree to continue to perform the Agreement.
50. Senior Representatives' Negotiations: If the dispute can not be resolved within a period of fifteen (15) days, the parties hereby agree to appoint senior representatives forthwith to undertake to resolve the dispute by amicable negotiations as outlined herein.

**APPENDIX B – Purchase Order Terms & Conditions**

(please refer to this number when making inquiries)

51. Mediation: If the dispute can not be resolved within a period of thirty (30) days following the appointment of senior representatives for the parties pursuant to clause 18.2, the parties agree to attempt to resolve the dispute by structured negotiation with the assistance of a mutually agreeable mediator. If the parties can not agree as to the identity of the mediator, either party may apply to the Nunavut Court of Justice to have the Court appoint a mediator for the parties.
52. Binding Arbitration: If the dispute can not be resolved within a period of thirty (30) days or such longer period as may be agreed to by the parties following appointment of the mediator by the parties or the court, either party may by written notice to the other refer the dispute to binding arbitration by a single arbitrator. If the parties cannot agree upon the identity of the single arbitrator, then such arbitrator shall be appointed by reference to the Nunavut Supreme Court;
53. The arbitration shall be conducted under the rules Arbitration Act, R.S.N.W.T. (Nu.) 1988, c. A-5. The language of the arbitration shall be English and the location of the arbitration shall be insert location, unless the parties otherwise agree in writing.
54. Any dispute may be submitted to arbitration except:
  - a) The breach or alleged breach of the confidentiality and non-disclosure provisions of this Agreement;
  - b) The fundamental breach or alleged fundamental breach of this Agreement by either party; and,
  - c) Where the Agreement has been terminated by NHC pursuant to this Agreement.
55. Unless the parties otherwise agree in writing, the award of the arbitrator shall be final and binding upon the parties and not subject to appeal.

**SUPPLEMENTARY TERMS OF PAYMENT**

1. The successful supplier shall be paid in two installments:
  - a) The first installment of fifty percent (50%) of the total contract amount **may** be released after the receipt of official proof of the delivery of the goods to the carrier. All packing slips, crate list and shop drawings shall be submitted to NHC once the goods are delivered to the sealift carriers before payment will be released. NHC will review to ensure it is accurate and satisfactory prior to the release of payment.
  - b) Final installment of fifty percent (50%) of the total contract amount may be released upon the **satisfactory** inspection of the goods by an NHC designate. On request of the supplier a date will be set by mutual agreement of the NHC and the supplier for joint inspection of the received goods. **After inspection, NHC will generate a list of overages, shortages, damaged items, and unaccepted substitutions which will be submitted to the supplier. The Supplier may choose not to be involved in the inspection, but by doing so has agreed to abide by the findings of the NHC or LHO/LHA.**
  - c) The supplier is required to submit invoices by individual commodity groups. A maximum of two invoices per commodity (one for the first 50% complete with proof of the delivery of the goods to the carrier and a second final invoice).
  - d) Both invoices are to be sequentially numbered and are to reflect the item #, description, quantity and unit prices as contained in the Commodity Unit Price Form.
  - e) All invoices for payment are to be sent to;  
**Sanikiluaq Housing Association**  
P.O. Box 149  
Sanikiluaq, Nu X0A 0W0  
[qhamanager@xplor.net.ca](mailto:qhamanager@xplor.net.ca)
  - f) For an order to be considered complete, all material must be received, i.e. no back orders will be allowed without prior written approval from the NHC or LHO/LHA
  - g) The contract number and purchase order number must be shown clearly on all invoices, bills of lading, or any other relevant document or correspondence.
  - h) Invoices must be submitted no later than to 31 Dec 2021.

**APPENDIX B – Purchase Order Terms & Conditions**

(please refer to this number when making inquiries)

2. Provided all terms and conditions on the part of the Supplier have been complied with, each invoice, shall be paid thirty (30) calendar days after receipt of the invoice, or thirty (30) calendar days after delivery of the goods, whichever is later.
3. Provided all terms and conditions on the part of the Supplier have been complied with, invoices from a Nunavut Business, as defined by the NNI Regulations, shall be paid twenty (20) calendar days after receipt of the invoice, or twenty calendar days after receipt of the goods, whichever is later.
4. In addition to its rights under this Contract, the NHC specifically reserves the following rights:
  - a) to deduct or set off any monies owed or due to the NHC from any monies owed to the Supplier under this or any other contract;
  - b) to do any act the NHC deems necessary to remedy or rectify any failure of the Supplier to perform its obligations under this Contract, and to set off the costs of such remedy or rectification from any monies owed to the Supplier under this or any other contract;
  - c) to hold back, in whole or in part, any payment due or becoming due to the Supplier without penalty, liability or expense in the event the Supplier is, in the opinion of the NHC, failing to perform its obligations under this Contract; until such time as the breach is cured to the full satisfaction of the NHC.
5. The hold back will be disbursed upon:
  - a) satisfactory delivery of the goods in accordance with this Contract;
  - b) all damaged items are replaced and/or repaired so that they are deemed to be in compliance with the specifications; or
  - c) upon final delivery and inspection to the satisfaction of the NHC.
6. The NHC's rights under this Contract are in addition to any rights and remedies it may have in law or equity.
7. If product substitutions are received without prior written approval from NHC, they will be denied, and no payment shall be released until the product is replaced at the expense of the successful contractor. For further clarity, the replacement of the incorrect items will be airlifted to the community and payment withheld until the issue is resolved at the sole discretion of NHC.

# **APPENDIX**

## **"C"**

### **MATERIALS, QUANTITIES**

**O&M COMMODITY OFFER FORM**

2021 SEALIFT MATERIAL

QAMMAQ HOUSING ASSOCIATION (SANIKILUAQ)

Offerer/Supplier:

Commodity:

F.O.B. HOUSING  
ORGANIZATION WAREHOUSE

MMOS NUMBER	QUANTITY	UNIT	DISCRIPTION	Unit Price	ITEM TOTAL
APP02	3	EACH	RANGE - 30" ADMIRAL or GE Coil Bumer G.E.		
APP04	3	EACH	Fridge white energy star rated 30" G.E. 61 3/4 x 29 1/8 x 28, top-freezer refrigerator		
APP45	10	EACH	ELEMENT - 8" PLUG-IN BURNER 3713-636 5-TURN 240V 2600W 3713-805		
APP49	10	EACH	ELEMENT - 6" PLUG-IN BURNER PS-15-M-BK PLUG TYPE T---D 3713-592		
APP80	5	EACH	BURNER CONTROL 318293811 8.9-11.0A		
APP87	25	EACH	TERMINAL BLOCK KIT LONG LEAD 318112500		
APP10	2	EACH	Fan Motor for fridge, Model# WR60M126		
APP38	2	EACH	Oven Thermostat Mode#: PS437315		

TOTAL THIS PAGE: ---->

\*COMMODITY TOTAL: ---->

NOTE: ALL UNIT PRICES ARE TO BE STATED AS F.O.B. COMMUNITY, DELIVERED TO THE HOUSING ORGANIZATION WAREHOUSE. SHIPPING IS NOT TO BE SHOWN AS A SEPARATE PRICE.

\*NOTE: THIS AMOUNT IS TO BE ENTERED ON OFFER FORM AS COMMODITY TOTAL. THIS AMOUNT IS NOT TO INCLUDE THE GST.

## O&M COMMODITY OFFER FORM

2021 SEALIFT MATERIAL

QAMMAQ HOUSING ASSOCIATION (SANIKILUAQ)

Offerer/Supplier:

Commodity: Architectural & Related

**F.O.B. HOUSING  
ORGANIZATION WAREHOUSE**

MMOS#	QTY	UNIT	DESCRIPTION	Unit Price	ITEM TOTAL
CA550	8	Bag	Rockwool R14 24" 60 sqft/ bag		
CA551	8	Bag	Rockwool R24 24" 60 sqft/ bag		
CA552	8	Bag	Rockwool R14 16 " 59.7 sqft /bag		
CA553	8	Bag	Rockwool R24 16 " 59.7 sqft/bag		
WO381	40	EACH	PLYWOOD FIR 5/8" GIS 4ft x 8ft sheet		
WO382	40	EACH	1/2" PLYWOOD GIS 4ft x 8ft sheet		
WO386	40	EACH	1/4" PLYWOOD GIS 4ft x 8ft sheet		
WO384	40	EACH	3/8" PLYWOOD GIS 4ft x 8ft sheet		
WO528	20	EACH	PINE CLEAR EASTERN - 1" x 8" x 8'		
WO698	40	EACH	Pressure Treated WOOD (GOODFELLOW) - 2" x 10" x 16'		
WO699	80	EACH	Pressure Treated WOOD(GOODFELLOW) - 2" x 6" x 16'		
WO701	50	EACH	Pressure Treated WOOD(GOODFELLOW) - 2" x 8" x 16'		
WO695	40	EACH	Pressure Treated WOOD(GOODFELLOW) - 2" x 12" x 16'		
AB149	2	ROLL	EPDM Rubber membrane, thickness is 60 mil (1/16" inch)		
			EPDM roll size is 10ft wide x 50 ft long - no substitute		

TOTAL THIS PAGE: ----->

\*COMMODITY TOTAL: ----->

**NOTE: ALL UNIT PRICES ARE TO BE STATED AS F.O.B. COMMUNITY, DELIVERED TO THE HOUSING ORGANIZATION WAREHOUSE. SHIPPING IS NOT TO BE SHOWN AS A SEPARATE PRICE.**

**\*NOTE: THIS AMOUNT IS TO BE ENTERED ON OFFER FORM AS COMMODITY TOTAL. THIS AMOUNT IS NOT TO INCLUDE THE GST.**

## O&M COMMODITY OFFER FORM

2021 SEALIFT MATERIAL

QAMMAQ HOUSING ASSOCIATION (SANIKILUAQ)

Page 3 of 9

Offerer/Supplier:

Commodity: Automotive Related

**F.O.B. HOUSING ORGANIZATION WAREHOUSE**

MMOS NUMBER	QUANTITY	UNIT	DESCRIPTION	Unit Price	ITEM TOTAL
AU550	12	LITRE	OIL 5W30		
AU700	4	EACH	General Grabber AT2 LT245/70R17 ( No Substitute LT245/70R17		
AU901	4	EACH	Victor tire plugs refill 30 pk {cnd tire} 009-2102-8 (Found in Canadian Tire)		
AU904	1	EACH	Victor Heavy Duty tire repair kit {tools} 009-2134-2 (Found in Canadian Tire)		
AU931	48	Litre	Cleanflo Diesel fuel conditioner 1L bottles		
AU932	24	Jug	Windshield washer fluid 4L jug		
AU933	6	Each	Motorcraft P926D Air filter		
AU934	12	Each	ACDelco PF63E Oil Filter		
AU					

TOTAL THIS PAGE: ---->

\*COMMODITY TOTAL: ---->

**NOTE: ALL UNIT PRICES ARE TO BE STATED AS F.O.B. COMMUNITY, DELIVERED TO THE HOUSING ORGANIZATION WAREHOUSE. SHIPPING IS NOT TO BE SHOWN AS A SEPARATE PRICE.**

**\*NOTE: THIS AMOUNT IS TO BE ENTERED ON OFFER FORM AS COMMODITY TOTAL. THIS AMOUNT IS NOT TO INCLUDE THE GST.**



**O&M COMMODITY OFFER FORM**

2021 SEALIFT MATERIAL

QAMMAQ HOUSING ASSOCIATION (SANIKILUAQ)

Offerer/Supplier:

Commodity:

F.O.B. HOUSING  
ORGANIZATION    WAREHOUSE

MMOS NUMBER	QUANTITY	UNIT	DESCRIPTION	Unit Price	ITEM TOTAL
BLK350	25	EACH	BLK IRON CLOSED NIPPLE - 2" 2" 3239-757		
HT009	6	EACH	4" x 10" GREY FLOOR DIFFUSER 4" x 10" RG1851		
HT010	6	EACH	3" x 10" GREY FLOOR DIFFUSER 3" x 10" RG1850		
HT012	12	EACH	GRANDBY TANK VENT ALARM (WHISTLE) 1 1/4" AND 2" NPT E500-999UA		
HT020	2	EACH	AQUASTAT FAN LIMIT Model # L6006A1145		
HT021	2	EACH	HOT WATER CONTROL 11B76-1		
HT035	3	EACH	OLSEN DOWNFLO OIL FIRED FURNACE Model #WML - 80		
HT1005	6	EACH	WEIL-MCLEAN INDIRECT HWT T-STAT 633-500-024		
HT033	4	EACH	WEIL-MCLEAN INDIRECT HWT T-STAT		
HT034	6	EACH	WEIL-MCLEAN INDIRECT HWT T-STAT		
HT571	24	EACH	NOZZLE .65 - 80A		
HT570	24	EACH	NOZZLE - 65-80W		
HT261	24	EACH	general oil filter canister 1a-25 b & 1a-25 a		
HT876	10	EACH	1034 NORMALLY CLOSED ZONE VALVES-FLARED HONEYWELL		
HT825	8	EACH	8A05A-1 - Emerson White Rodgers Relay/Transformer, 120VAC, Enclosed, SPDT		
HT251	6	Box	20 x20 x 1 pleated furnace filters		
HT250	6	Box	20" x18" x 1" pleated furnace filters		
PA063	12	EACH	BRUSH SASH - 2 1/2"		
TO166	10	each	sootmaster paper filter bags (356212) pack of 5		
HT999a	12	each	Oil tank gauge		

→

**NOTE: ALL UNIT PRICES ARE TO BE STATED AS F.O.B. COMMUNITY, DELIVERED TO THE HOUSING ORGANIZATION WAREHOUSE. SHIPPING IS NOT TO BE SHOWN AS A SEPARATE PRICE.**

**\*NOTE: THIS AMOUNT IS TO BE ENTERED ON OFFER FORM AS COMMODITY TOTAL. THIS AMOUNT IS NOT TO INCLUDE THE GST.**

## O&M COMMODITY OFFER FORM

**2021 SEALIFT MATERIAL**

**QAMMAQ HOUSING ASSOCIATION (SANIKILUAQ)**

Page 5 of 9

Offerer/Supplier:

Commodity:

**F.O.B. HOUSING  
ORGANIZATION WAREHOUSE**

MMOS NUMBER	QUANTITY	UNIT	DESCRIPTION	Unit Price	ITEM TOTAL
AB114	12	EACH	ABS 2" 45 degree elbows		
TO520	24	EACH	Forney 70469 Nylon Tube Brush with Wire Loop Handle, 8-1/2-Inch by 3/4-Inch		
TO521	24	EACH	Hot Max 26207 8-1/2-Inchx1/2-Inch Tube Brush, Nylon with Wire Loop Handle		
PL778	24	EACH	STRAINER ASSEMBLY 3-1/2" BASKET C/W TAIL PIECE		
PL002	12	EACH	Paste brush		
PL012-A	1	EACH	INSULATED SEWAGE TANK C/W HEAT ELECTRIC TRACE		
PL012-B	1	EACH	INSULATED SEWAGE TANK C/W GLYCOL HEAT TRACE		
PL011	4	EACH	POTABLE WATER TANK		
PL430	2	EACH	WATER HEATER OIL JWF307 1B-32		

**TOTAL THIS PAGE:** ----->

**\*COMMODITY TOTAL:** ----->

**NOTE: ALL UNIT PRICES ARE TO BE STATED AS F.O.B. COMMUNITY, DELIVERED TO THE HOUSING ORGANIZATION WAREHOUSE. SHIPPING IS NOT TO BE SHOWN AS A SEPARATE PRICE.**

**\*NOTE: THIS AMOUNT IS TO BE ENTERED ON OFFER FORM AS COMMODITY TOTAL. THIS AMOUNT IS NOT TO INCLUDE THE GST.**

# O&M COMMODITY OFFER FORM

**2021 SEALIFT MATERIAL**

**QAMMAQ HOUSING ASSOCIATION (SANIKILUAQ)**

Offerer/Supplier

Commodity:

**F.O.B. HOUSING ORGANIZATION WAREHOUSE**

MMOS#	QTY	UNIT	DESCRIPTION	Unit Price	ITEM TOTAL
PA183	6	EACH	18.9L Pails     Denalt 2 in 1 Paint & Primer		

**NOTE: ALL UNIT PRICES ARE TO BE STATED AS F.O.B. COMMUNITY, DELIVERED TO THE HOUSING ORGANIZATION WAREHOUSE. SHIPPING IS NOT TO BE SHOWN AS A SEPARATE PRICE.**

TOTAL T    ---->   

COMMODITY TOTAL    ---->   

\*NOTE: THIS AMOUNT IS TO BE ENTERED ON OFFER FORM AS COMMODITY TOTAL.  
THIS AMOUNT IS NOT TO INCLUDE THE GST.

**O&M COMMODITY OFFER FORM**

2021 SEALIFT MATERIAL

QAMMAQ HOUSING ASSOCIATION (SANIKILUAQ)

Offerer/Supplier:

Commodity:

**F.O.B. HOUSING ORGANIZATION WAREHOUSE**

MMOS#	QTY	UNIT	DESCRIPTION	Unit Price	ITEM TOTAL
TO505	10	EACH	WEN10 in. 40-Tooth Carbide-Tipped Saw Blade for Miter Saws and Table Saws		
TO506	3	EACH	Drill America 12 in. L x 32 TPI Bi-Metal Hacksaw Blade (10-Pieces)		
TO507	1	PACK	Wiss Straight cut aviation snips 3 pak		
TO508	1	EACH	Rigid 3/16 in. to 1-1/8 in. Model 15 Screw Feed Tubing and Conduit Cutter		
TO509	1	PACK	Ridgid 1/8 in. to 2 in. Model 2-A Adjustable Heavy-Duty Pipe Cutter		
TO510	1	EACH	Rigid 2 in. to 4 in. Model 4-S Heavy-Duty Pipe Cutter		
TO511	2	EACH	Rigid 3/16 in. to 15/16 in. Model 104 Close Quarters Tubing Cutter		
TO512	2	SET	5/8 in. Dia x 50 ft. Element Contractor Farm Premium Duty Water Hose		
TO513	2	SET	Tekton 3/16-1/2 in., 5-10 mm Nut Driver Set (14-Piece)		
TO514	2	SET	Insulated Pliers and Cutters Set (3-Piece)		
TO515	2	SET	8-pc GrooveLock Pliers Set		
TO516	30	EACH	SAFTEY GLASSES Uline #S-21432C 3M brand		
TO517	2	EACH	Milwalkee Adjustable Wrench Set (4-Piece)		
TO518	2	EACH	Screwdriver and Nut Driver Tool Set with Magnetizer (16-Piece)		
TO519	2	EACH	7/16 in. to 1 in. High Speed Steel Ball Joint Taper Reamer Bit		
TO522	2	EACH	MAKITA 3-inch x 24-inch Belt Sander Model # 9924 DB		
TO523	10	EACH	Diablo 3-inch x 24-inch 120 Grit Sand Paper Belt (2 Pack)		
TO524	10	EACH	Diablo 3-inch x 24-inch 80 Grit Sand Paper Belt (2 Pack)		
TO897	4	EACH	Featherlite fibreglass step ladder 4 Feet grade I Model #FL-3110-04		
TO898	4	EACH	Featherlite fibreglass step ladder 6 Feet grade I Model #FL-3110-06		
TO899	4	EACH	Featherlite fibreglass step ladder 8 Feet grade I Model #FL-3110-08		
AU112	30	EACH	Motorcraft Spark Plug Part Number: 146838-05104002		
TO347	5	EACH	Olfa 25mm Snap-Off Ultra-Sharp Black Blades, 20 pack		
<b>TOTAL THIS PAGE</b>					

NOTE: ALL UNIT PRICES ARE TO BE STATED AS F.O.B.

COMMUNITY, DELIVERED TO THE HOUSING ORGANIZATION

----->

WAREHOUSE. SHIPPING IS NOT TO BE SHOWN AS A SEPARATE PRICE.

\*NOTE: THIS AMOUNT IS TO BE ENTERED ON OFFER FORM AS COMMODITY TOTAL.  
THIS AMOUNT IS NOT TO INCLUDE THE GST.

# O&M COMMODITY OFFER FORM

2021 SEALIFT MATERIAL

QAMMAQ HOUSING ASSOCIATION (SANIKILUAQ)

Offerer/Supplier:

Commodity: Office & Cleaning Supplies

**F.O.B. HOUSING  
ORGANIZATION WAREHOUSE**

MMOS #	QTY	UNIT	DESCRIPTION	Unit Price	ITEM TOTAL
JA150	1	EACH	Staples Vertical Legal File Cabinet, 4-Drawer, Grey		
JA149	2	EACH	Luxor (WB4848W) 48" x 48" Wall-Mounted Magnetic		
JA076	2	EACH	Staples Mop Bucket, Yellow, 35 Quart		
JA089	6	pack	Post-it stamps 3"x3"		
JA090	3	pack	Post-it stamps 3 7/8" x 5 7/8"		
JA115	2	pack	Post-it stamps 2" x 2 1/2"		
JA093	8	each	Compressed air duster, 12 oz can		
JA120	30	each	Scotties 2 Ply White tissues 21cm x 18.7cm		
JA048	6	each	Uline 33" x 38" black outdoor garbage bags Model S - 13524		

TOTAL THIS PAGE ---->

COMMODITY TOTAL ---->

**NOTE: ALL UNIT PRICES ARE TO BE STATED AS F.O.B.  
COMMUNITY, DELIVERED TO THE HOUSING ORGANIZATION  
WAREHOUSE. SHIPPING IS NOT TO BE SHOWN AS A SEPARATE PRICE.**

**\*NOTE: THIS AMOUNT IS TO BE ENTERED ON OFFER FORM AS COMMODITY TOTAL.  
THIS AMOUNT IS NOT TO INCLUDE THE GST.**

**O&M COMMODITY OFFER FORM**

**2021 SEALIFT MATERIAL**

**QAMMAQ HOUSING ASSOCIATION (SANIKILUAQ)**

Offerer/Supplier:

Commodity:

MMOS #	QTY	UNIT	DESCRIPTION	F.O.B. HOUSING	
				ORGANIZATION	WAREHOUSE
EL049	2	EACH	Schneider Electric Square D 100 Amp Main Breaker Only Plug-on Neutral Circuits Loadcentre with 32 Spaces, 53 Maximum Model # CQO132M100PC		

TOTAL THIS PAGE: ----->

\*COMMODITY TOTAL: ----->

NOTE: ALL UNIT PRICES ARE TO BE STATED AS F.O.B. COMMUNITY, DELIVERED TO THE HOUSING ORGANIZATION WAREHOUSE. SHIPPING IS NOT TO BE SHOWN AS A SEPARATE PRICE.

\*NOTE: THIS AMOUNT IS TO BE ENTERED ON OFFER FORM AS COMMODITY TOTAL. THIS AMOUNT IS NOT TO INCLUDE THE GST.

# **APPENDIX**

**"D"**

## **CRATING REQUIREMENTS**

# CRATING REQUIREMENTS

## GENERAL

1. No component material will constitute part of the packaging (excluding lumber crates).
2. In view of the high cost of transportation in Nunavut, Suppliers shall ensure that the maximum cubic capacities of all crates are utilized.
3. Suppliers shall try to find means to reduce the cost of transportation of materials (i.e. discount prices). All materials must be part of one particular commodity only. Mixing Commodities or **Projects Will** not be permitted.

## NO VOID SPACES WILL BE PERMITTED

4. All packaging/crating of restricted articles and dangerous goods must conform to the Federal Government's ***Transportation of Dangerous Goods Act*** which came into effect July 1, 1985. All documentation, labeling and packaging must conform up to and including the regulations. All modes of transport must be considered when packaging.
5. All restricted articles and dangerous goods carried by truck, air or sea transport in Nunavut must be packaged or crated in accordance with the Nunavut's ***Transportation of Dangerous Goods Act*** and Regulations.
6. All documentation, labeling and packaging of controlled products must conform to the **Federal Government Controlled Products Regulations** of the ***Hazardous Product Act*** which came into effect October 1, 1988.
7. All crating material (plywood) specified shall be "D" grade plywood or new OSB with a minimum thickness of 5/8" or 1/2" (as specified) and manufactured in Canada only are acceptable. All cargo units shall be packaged so as to minimize voids, and blocked, so as to prevent the internal movement or shifting of goods.
8. Mixed goods in one cargo unit shall be stored so as to prevent damage using blocking and dividers. Separation of mixed goods shall be effected so as to prevent cross contamination such as, but not limited to those caused by stains and odors.
9. All cargo units shall be packaged without significant voids at the top to prevent crushing and to maximize the weight to cube ratio as much as possible to 400kg per cubic meter.



## 10. SUGGESTED PACKING REQUIREMENTS

### Outside Storage (Crates)

- cement/cinder blocks
- Dimensional lumber
- drummed compounds (Glycol)
- prefab tanks (water/fuel/sewage)
- batteries
- steel or iron pipes and fittings
- roofing material
- electrical appliances
- furnaces/boilers
- hot water maker
- fibreglass insulation
- sheet rock
- pumps
- drywall
- office equipment/ stationary and printed matter
- flooring materials
- pre-finished woodwork such as mouldings, doors (interior/exterior), windows and cabinetry
- misc. hardware
- vehicle parts/supplies
- cement in bags
- heating supplies
- repair parts (electrical and mechanical)
- chemicals
- electrical supplies
- glass and glassware plumbing supplies
- all tools
- other items as required

### Special Cargo (Dangerous Goods)

- Dangerous Goods cargo have to be crated separately
- Items such as paints/varnishes, caulking, sealants, glues, adhesives are considered as dangerous goods
- Crates are to be properly labeled, documented and shipped in accordance with the Transportation of Dangerous Goods Act and Regulations respecting the handling, offering for transport and transporting of dangerous goods
- The description of cargo, the community, IMC/IPIN numbers, UN number, page number and flashpoint must appear on all documentation.
- Dangerous goods will not be consolidated with any other cargo in containers.

## **Packing / Shipping Guidelines**

### **Documentation**

Shippers will ensure that documentation accompanying all shipments is completed and includes:

- a) Shippers name and address
- b) Consignees name and address
- c) Port of discharge
- d) Crate identification number
- e) Number of pieces and description of cargo
- f) Individual weight of each piece (in metric)
- g) Individual dimensions/volume of each piece (in metric)
- h) Label information from each crate e.g. Glass Handle with Care;  
Dangerous Goods - red label; Paint - do not freeze
- i) a value for each piece which is over \$500.00 must be declared at this time for claims purposes
- j) Only the consignee and one destination are permitted on each delivery bill.

### **Crate Skids**

1. Shall be solid lumber skids S4S nominal thickness and width 4"x 4". No build up of smaller pieces will be accepted.
2. Crates less than 8' in length shall carry 2 skids.
3. Crates 8' or greater but less than 16' shall carry 3 skids.
4. Crates 16' or longer shall carry minimum 4 skids.

### **Crate Bases**

1. 2"x 4" stringers for base framing to be spaced 16"o/c max.

### **Crate Strapping**

1. All crates, subsequent to screwing shut, are to be steel strapped.
2. All crates 16' or longer shall carry 4 steel straps of minimum 1 ¼" width.
3. Crates less than 16' but 8' or greater shall carry 3 steel straps of minimum 1 ¼" width.
4. Crates less than 8' shall carry 2 steel straps of minimum 1 ¼" width

## Sketch of Crates

8. Style "A", "B" and "C" crates are built as per sketches. No exceptions will be permitted unless prior authorization in writing is obtained from the Nunavut Housing Corporation or Local Housing Association/Housing Authority.

## Packing Slips

9. All crates shall contain a complete, clear and unmarked packing slip. Packing slips shall be of 75g/m<sup>2</sup> long grain white bond paper. Subject packing slips shall be located in both the interior and exterior of Type A and Type C enclosed crates. For Style B crate and lumber lifts, the packing slips shall be located on two sides of all crates and lifts. Packing slips shall be securely stapled in a waterproof, transparent envelope and must be stapled with one staple in each corner.

## Style "A" Crates

1. Screws with a minimum length of 2" must be used in the construction of crates. Minimum 3" wood screws to be used to attached side-walls of crate to the crate base. Minimum 4" spiral grooved nails to be used to secure the base to the skids. Top of the crate to be fastened using minimum 3" wood screws. Divergent point staples may be used to attach 1 "x 4" strapping to the exterior of the crate otherwise 1 ¼" wood screws may be used.

Any seam created on lids during crating must be sealed with plywood, ¾" thick, and should, where permissible extend 6" on either side of the seam and run the length of the seam. Seam plated shall be attached using 1 ¼" wood screws. (Note: 5/8" plywood will be permitted provided steel strapping is tightened sufficiently to be level with 5/8" plywood).

## Style "B" Crates

1. Screws with a minimum length of 2" must be used in the construction of crates. Minimum 3" wood screws to be used to attach side walls of crate to the base. Minimum 4" wood screws to be used to secure base to the skids. No staples will be permitted.
2. No component will constitute part of the packaging.

## Style "C" Crates

1. Screws with a minimum length of 1 ¾" must be used in the construction of the crates. Minimum 3 ½" wood screws to be used to attach side-walls of crate to the crate base. Minimum 4" wood screws to be used to secure the base to the skids.

Top of the crate to be fastened using minimum 3" screw.

2. Any seams created on lids or vertically on the sides during crate construction must be sealed with 2" thick dimensional lumber and should, where permissible, extend 2" nominal on either side of the seam and ~ the length of the seam. Seam plates shall be attached using 1 ½" wood screws.

### **Style "D" Crates**

1. For open frame crating, material shall be supported and blocked to prevent movement.
  - a. The GN and/or its representative must approve any major deviation. All materials used in packaging and crating shall be new, unless otherwise agreed to by the NHC. All packaging shall be completed so as to minimize outside dimensions. Any deviation is at the NHC discretion and is valid on a per Crate basis.
  - b. If not specified, packaging is to be determined by the contractor according to its best expertise and to be determined with discussion the NHC where there may be question.

### **Lumber**

11. STEEL corners must be used to protect all lumber from damage by strapping. Steel corners shall be SIGNODE EG-3A or ACME 26B.

### **Crating Specifics**

12. For Style "A", "B" and "C" crates, all items susceptible to damage from moisture must be shrink wrapped minimum 6 ml poly (CGSB approval not required) and heat sealed prior to being crated. Particular attention must be given to the following items

Gypsum drywall board all types  
Polyfills  
Joint compound  
Kitchen cabinets  
Vanities and counter tops

Window Crates Only – In addition to being packaged in Style "A" or "C" crate – 1"x 4" framing at 16 o/c maximum to be fastened to bottom of 4"x 4" skids using minimum 2 ½" wood screws.

13. Cabinet Crates Only – all crates requiring a seam plate on the lid should be glued and caulked so as to prevent water penetration.

### **Other Cargo (Special)**

Maximum heavy lift is 13.5 metric tons unless otherwise agreed.

Laminated Beams - Must be covered with Tyvek type wrapping material for protection from the elements.

Other unique materials may be specifically identified and special shipping instructions will be attached to the commodity.

PLEASE COMPLY WITH THIS SECTION. FAILURE TO DO SO MAY RESULT IN A DELAY IN PAYMENT OR RESULT IN THE RETURN OR RE-SUPPLY AS SET OUT UNDER THIS TENDER TO DAMAGED OR MISSING MATERIAL.

# STYLE "A" CRATE

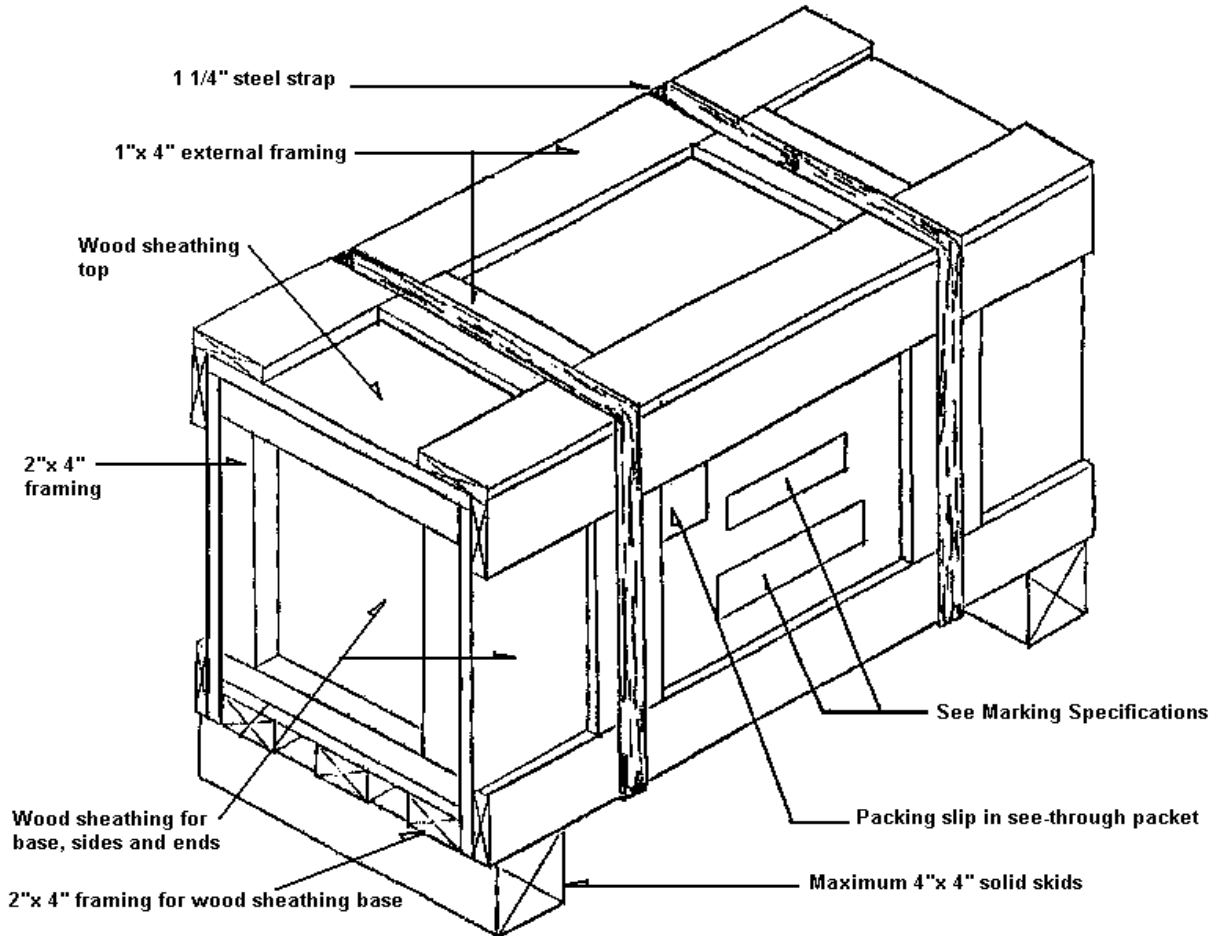

# STYLE "B" CRATE

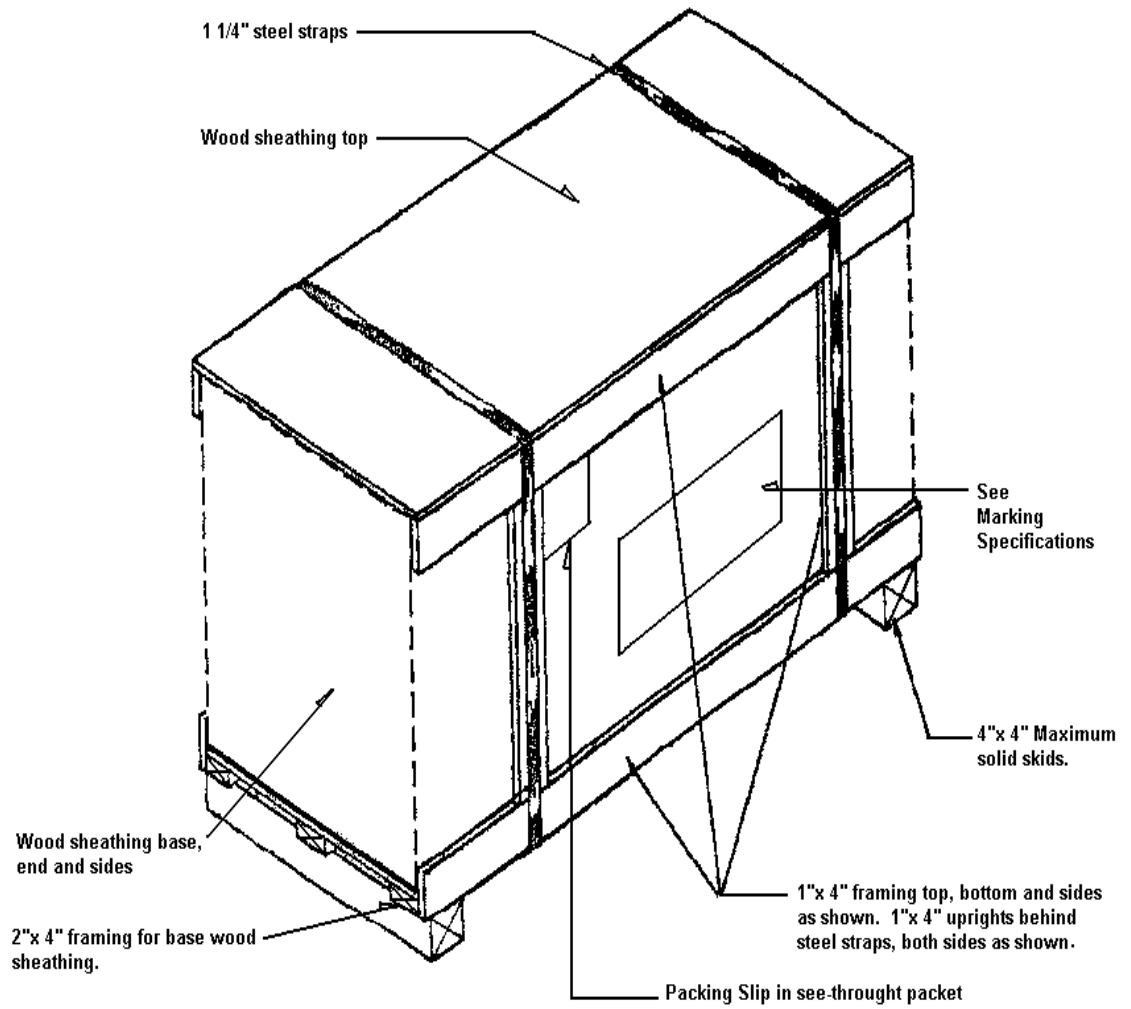

# STYLE "C" CRATE

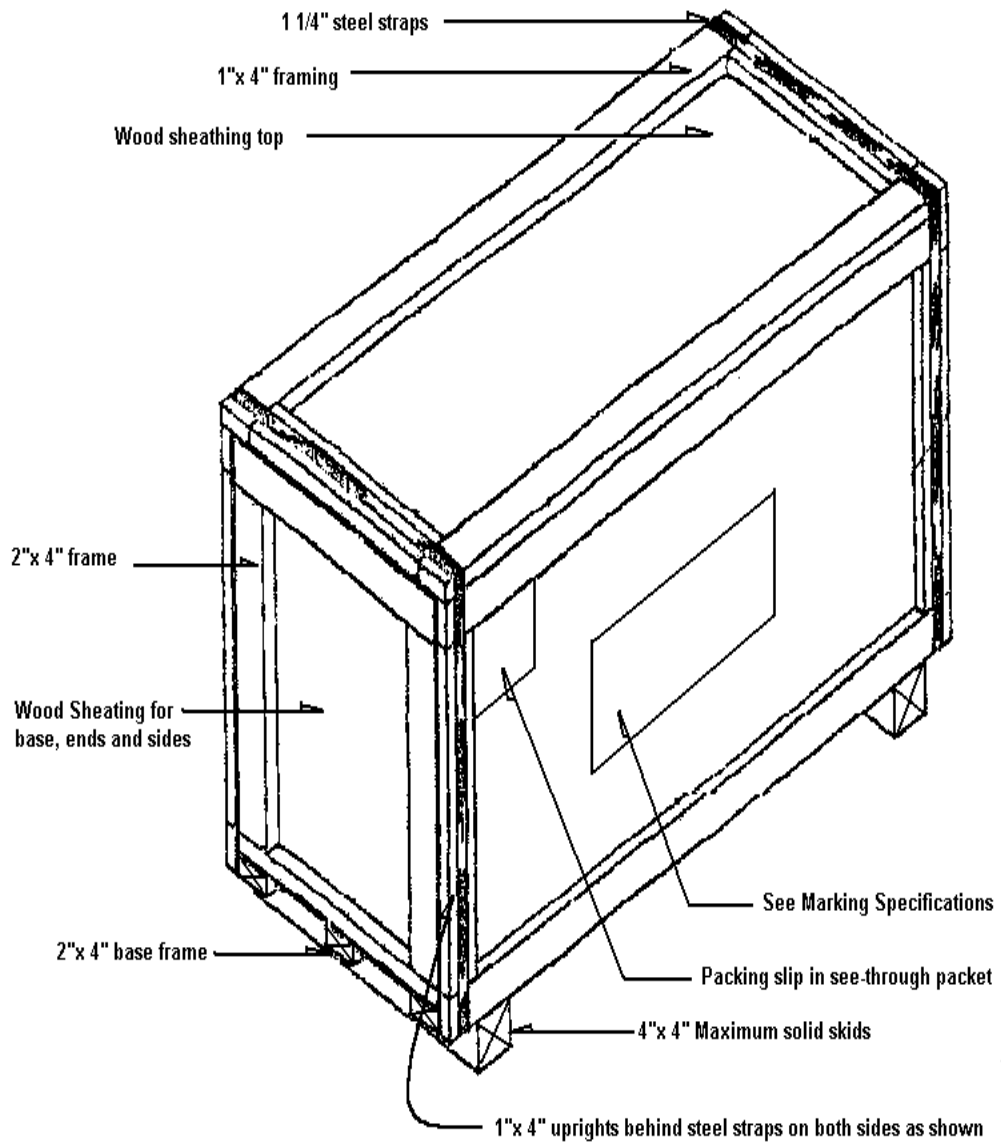



## OPEN STYLE CRATE "D"

- 2" X 4" spruce for frame along sides and top of crate and 2" X 2" on bottom ends to be used and placed on the inside of crate.
- 2" X 4" Stringers for base framing to be spaced 16" o/c maximum
- All wood sheathing to be 1/2"
- Minimum 3 skids per crate.
- For crates longer than 8', space skids 4' o/c.
- Minimum 2 steel straps per crate, to be placed along skids.
- For crates longer than 8', space steel straps every 4' o/c along skids.
- Minimum 13/4" grooved nails for crate construction, 3 1/2" spiral grooved nails to attach side and end wall together. 4" spiral grooved nails to be used to secure base to skid.
- Top of crate to be fastened using 2" #10 Robertson wood screws.
- I.D. Labels to be pasted on the top right hand corner of each side, on 1 end and on top of crate.
- Packing slip inside waterproof, self-adhesive, plastic envelope to be stapled on top left corner of crate using minimum 3/8" staples on each corner of envelope.
- Ensure that staples do not penetrate actual packing slip.

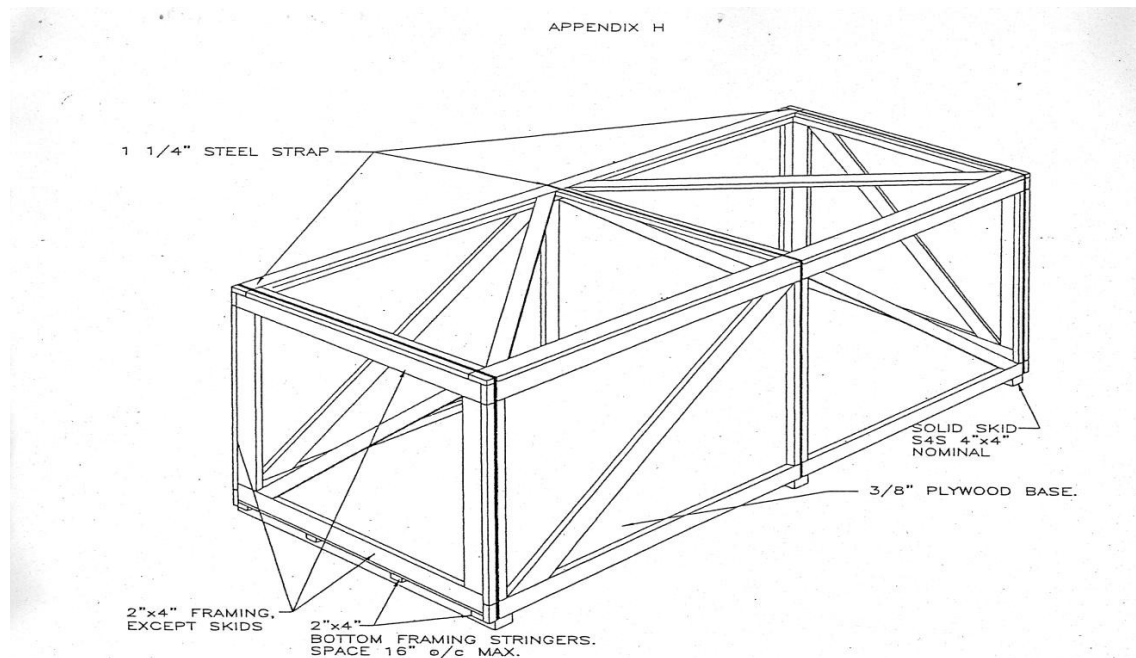

### STYLE "3" CRATE

- ALL WOOD FRAMING TO BE 2"x4"
- MINIMUM 1 3/4" SPIRAL GROOVED NAILS FOR CRATE CONSTRUCTION, 3 1/2" SPIRAL GROOVED NAILS TO ATTACH SIDEWALLS AND ENDWALLS TOGETHER. 4" SPIRAL GROOVED NAILS TO BE USED TO SECURE CRATE TO SKIDS.
- MINIMUM 3 SKIDS PER CRATE.
- MINIMUM 3 STEEL STRAPS PER CRATE. (AT SKID LOCATIONS AS SHOWN).

## MARKING SPECIFICATIONS

1. There shall be no signage or lettering except that which has been designated by NHC.
2. Lettering shall be minimum 3" in height and on a white background using waterproof industrial inks. **ABSOLUTELY NO hand lettering permitted.** Stencils may be applied by either roller or spray can.
3. All identification of Style "A" and "C" crates to be stenciled directly to the exterior of the crate on the two sides.
4. An identification plaque shall be utilized on all lumber lifts and Style "B" and style "D" crates rather than direct stenciling. Subject plaque shall adhere to the lettering and coloring specifications and be constructed of plywood and affixed with specified fastening devices NOT GLUED. Plate to be fastened to lumber lifts using minimum 2" wood screws.
5. Weights and cubes to be illustrated in metric and may be applied by hand. Supplier to ensure that actual and not approximate weights are noted.
6. All approved and proper labeling shall be of only PLASTIC LAMINATED SELF STICKING LABEL TYPES.
7. Suppliers to adhere to numbering sequence as established by NHC i.e.  
  
Crate Number 1-A  
Crate Number 2-A  
Crate Number 3-A
8. Maximum weight of any one crate not to exceed 3400 kg.
9. All labeling to be as follows:

BACKGROUND – WHITE / LETTERING – FLUORESCENT COLOR

(example)

**CORAL HAROUR HOUSING ASSOCIATION  
TOOLS AND EQUIPMENT  
CORAL HARBOUR**

**CUBE  
WEIGHT  
00.0 m<sup>3</sup>**

**0000.0 KG**

**CRATE 0 of 0**

## **PACKING SPECIFICATIONS**

1. All items (unless otherwise noted on material lists) shall be shipped in standard manufacturer's shipping cartons and shall not be consolidated.
2. Small items may be consolidated into a box for ease of stowage in a container or crate shall also contain an attached exterior packing slip describing the contents of the box. Small items are not to be placed loosely into a box but shall be put into a poly bag stapled closed.

## **SHIPPING INSTRUCTIONS**

1. Suppliers must ensure all shipping documents for containers, crates, packages, bundles and marked showing NHC's Purchase Order Number, Crate Number, accurate weight, accurate cubic measurement, final port destination (LHO/LHA) and crated/packaged as per NHC's packing and crating instructions.
2. One copy of cargo manifest/shipping bills to accompany the inland carrier Bill of Lading and to be delivered to the forwarding carrier or NHC's representative in the F.O.B. (freight pre-paid) community delivery.
3. All documentation accompanying shipments to the F.O.B. (freight pre-paid) point including cargo manifests, shipping bills, etc. must be segregated separately by Port of Destination and NHC Purchase Order must be manifested separately.
4. All cargo for delivery to a forwarding carrier - waybills, manifests and pro-bills, goods, etc. must be consigned as follows.

LHO/LHA

c/o (name and address of the carrier at F.O.B. (freight pre-paid point)

For Furtherance to LHO/LHA, Nunavut

The appropriate Purchase Order Number must appear on all copies of waybills, manifests, etc.

1. Transportation/shipping and handling of materials and all associated costs thereof are the responsibility of the Contractor unless otherwise noted. **Modes of transporting materials shall be decided by the Contractor unless by marine transport in which case Clause 2 of this Appendix shall apply.**
2. Whenever marine (water) transport is to be utilized, the Contractor shall use the Government of Nunavut specified carriers, and space shall be booked directly with the carriers, as follows:

**2.1 For the following communities in the following regions:**

**(Area A) High Arctic :** Arctic Bay, Clyde River, Grise Fiord, Nanisivik, Pond Inlet, Qikiqtarjuaq, Resolute Bay, and Kugaaruk as far as Nanisivik

and

**(Area C) Iqaluit:** Iqaluit

and

**(Area D) South Baffin:** Cape Dorset, Kimmirut, and Pangnirtung

and

**(Area E) Kivalliq:** Arviat, Baker Lake, Chesterfield Inlet, Coral Harbour, Rankin Inlet, Sanikiluaq, and Whale Cove

and

**(Area F) Kugaaruk:** Kugaaruk

and

**(Area H) Sanikiluaq:** Sanikiluaq

THE CARRIER IS:

**Nunavut Eastern Arctic Shipping (NEAS)**

by ships loading at the Port of Bécancour, Quebec

Contact: Marc-Andre Bougie

Phone: (877) 225-6327 (Toll Free)

Fax: (514) 523-7875

[mbougie@neas.ca](mailto:mbougie@neas.ca)

OR

**Nunavut Eastern Arctic Shipping (NEAS)**

by ships loading at the Port of Churchill, Manitoba

Contact: Marc-Andre Bougie

Phone: (877) 225-6327 (Toll Free)

Fax: (514) 523-7875

[mbougie@neas.ca](mailto:mbougie@neas.ca)

**NOTE: For transport to Sanikiluaq, services are from Port of Becancour.**

**2.2 For the following communities in the following regions:**

**(Area B) Foxe Basin:** Hall Beach, Igloolik and Naujaat:

and

**(Area G) Kitikmeot:** Bathurst Inlet, Cambridge Bay, Gjoa Haven, Kugluktuk, Taloyoak and Umingmaktok (Bay Chimo):

THE CARRIER IS:

**Nunavut Sealink and Supply Inc. (NSSI)**

By ships loading at the Port of Ste-Catherine, Quebec

Contact: Daniel Desgagnés

Phone: (450) 635-0833 or Toll free (866) 732-5438

Fax: (450) 635-5126

[daniel.desgagnes@transarctik.desgagnes.com](mailto:daniel.desgagnes@transarctik.desgagnes.com)

3. The annual shipping rates offered by marine carriers are dependent upon anticipated cargo quantities including the materials for construction projects; therefore, Contractors are to bid using the published sailing schedules and rates available from the above marine carriers. These schedules and rates are also available from the Department of Community & Government Services, Purchasing, Logistics & Contract Support Division, Contact: John Paton, Manager Logistics at (867) 975-5437.
4. If a Contractor uses a marine carrier other than the marine carrier specified by the GN under this Appendix without having obtained the GN's prior written authorization to do so, the Contractor shall be solely responsible for any extra freight costs, administrative costs or any other costs incurred by the GN which result either directly or indirectly from the Contractor's failure to use the GN specified marine carrier as set out in this Appendix. The Contractor shall issue a credit in favour of the GN for any monies saved by the Contractor obtained from using a marine carrier other than the specified marine carriers identified in this Appendix.
5. In exceptional or extraordinary circumstances, where a specified marine carrier's sailing schedule is in substantial conflict with the project schedule, the GN will review the circumstances, taking into account the potential adverse impact on the project and the specified marine carrier's interests, and, at its sole discretion, the GN may provide authorization to allow the relevant cargo to be shipped with a marine carrier other than a specified marine carrier; such authorization must be in writing and must be obtained prior to contracting for the marine transport.



PO 560000169

# SEALIFT SHIPPING

Terms and Conditions

## Delivery

Delivery of goods required must be made within the time, in the manner, and to the destination(s) stipulated herein. In order to facilitate payment of invoices, the supplier must provide a delivery slip signed by an authorized NHC employee, agent or marine transport company representative as proof of delivery to the F.O.B. point

## NEAS Cargo Services

**355 Boul. Alphonse-Deshaies**

**Port of Bécancour,**

**Bécancour, QC G9H 2Y7**

By the required date

When items ordered for marine transport are not delivered to the F.O.B. point in accordance with the terms of the contract (e.g. by the required delivery date), the NHC. will consider the supplier in default. The NHC. may do any act as it deems necessary to rectify such default including refusal of the goods or making alternate arrangements and this cost will be borne by the supplier in full. It also should be noted that delivery of the goods to the marine carrier after the contract delivery date, but prior to sailing date, MAY result in higher marine shipping charges to the NHC. Any such amount shall be borne by the supplier in full. Please note that the specific delivery date is based on the cut-off date for the last sailing into the specified communities.

FOB POINT: **Sanikiluaq, NU**  
MARINE CARRIER: **NEAS**  
DELIVERY REQUIRED: First Sailing  
DESTINATION: **Sanikiluaq, NU**

<p><b>THE SUPPLIER MUST CALL NEAS CARGO SERVICES, Bécancour, Quebec 24hrs. PRIOR TO THE DELIVERY OF GOODS. Tel: 877-225-6327</b></p>
<p><b>The supplier must provide the following information for each pallet, crate, skid, etc. ordered for Marine transport to the ultimate destination:</b></p> <p><b>Gross Shipping Weight----- Kg</b> <b>Width----- meters</b> <b>Length-----meters</b> <b>Height-----meters</b></p>